



Features

Capacitive Touch Control Panel

Simple to use control panel — select up to 10 precisely measured shot sizes

Patented Load Cell Technology

Enhanced load cell design delivers maximized durability while constantly monitoring product and adjusting flow rate to ensure a consistent and accurate pour every time

LED Display

Displays cabinet temperature and product volume information — including product low visual alerts

Easy to Clean

A manual clean mode feature prevents unwanted dispensing during wipe down

Removable Drip Tray

Easy-to-clean, one-piece drip tray with stainless steel insert

Santoprene™ Door Gaskets

Replaceable door gasket, tightly seals the refrigerated compartment
Replaceable door gasket, tightly seals the refrigerated compartment

Heavy-Duty Construction

Stainless steel exterior and interior with reinforced hinged door

Warranty

2-year materials and workmanship 5-year compressor, parts only

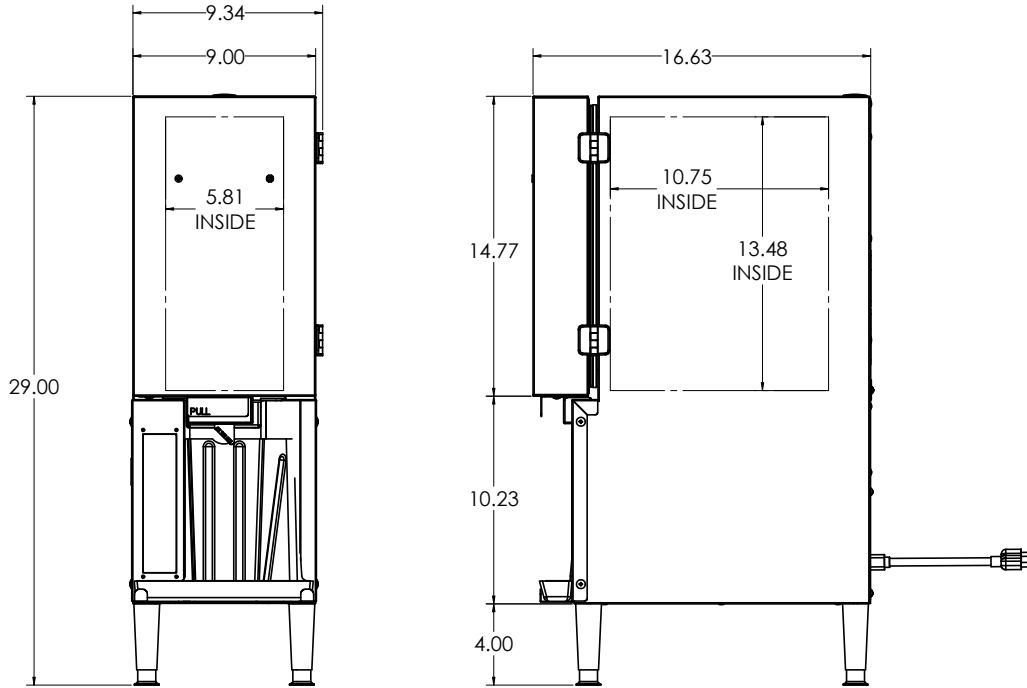

Technical Specifications

Electrical Requirements	115V/60Hz/1Ph/1.54A/NEMA 5-15 Plug
Product Dimensions	9.34"W x 29"H x 16.6"D (23.7cm x 73.7cm x 42.2cm)
Product Weight	60lbs (27.22kg)
Shipping Dimensions	14"W x 30"H x 24"D (35.6cm x 76.2cm x 61cm)
Shipping Weight	65lbs (29.48kg)
Shipping Cubic Dimensions	5.83ft ³ (0.17m ³)
Temperature Range	36 to 40 (2.2 to 4.4°C)
Refrigerant	R134A

Exterior Construction	Stainless steel with adjustable leveling legs
Interior Construction	Stainless steel
Doors	One (1) metal hinged swing door
Capacity	5 liter hopper
Door/Drawer Gasket	Santoprene™ gasket
Certifications	ETL/Intertek, Conforms to NSF/ANSI STD 20, Conforms to ANSI/UL 471, CSA Listed CAN/CSA-C22.2 No.120
Warranty	2-Year materials and workmanship / 5-Year compressor (parts only)

Part Number	Description
SK-2	Dairy Dispenser, 115V/60Hz/1Ph, 1 valve, 1.5L, adjustable legs, NEMA 5-15P

To learn more about **Dairy Dispenser**, visit silverking.com