



SK-1 Dairy Dispenser



SK-1 Dairy Dispenser

Precision Dispensing

The Silver King Dairy Dispenser is the newest innovation in dispensing technology. Featuring a patented load cell, cream is constantly weighed for accurate dispensing every time. No need to press a "Refill" button EVER AGAIN.

The patented valve has been simplified for fast bag changes, eliminating the risk of losing parts, and simplified cleaning.

The patented valve and load cell are powered by the new and improved Silver King controller to provide accurately measured shots of dairy on each dispense.

A new capacitive touch control panel increases operational efficiency with recipe programming for hot, flavored, iced coffee, and a fourth menu item. There are no mechanical buttons that can wear out. The display panel shows how much product is remaining and when a bag needs to be replaced.

Standard Features

- Patented load cell technology constantly measures how much product is in the hopper
- Simplified, patented valve makes bag changes fast and easy
- Simplified valve simplifies cleaning to a spray and wipe.
- No risk of losing parts or reassembling incorrectly with a new simplified valve design.
- New capacitive touch control panel
- Recipe programmed for hot, flavored and iced coffee with a fourth button for future menu growth
- Displays remaining product in hopper
- New and improved hopper makes creamer bag easier to load.
- Same narrow footprint as the original SKMCD1P/C1 Creamer.



Specifications

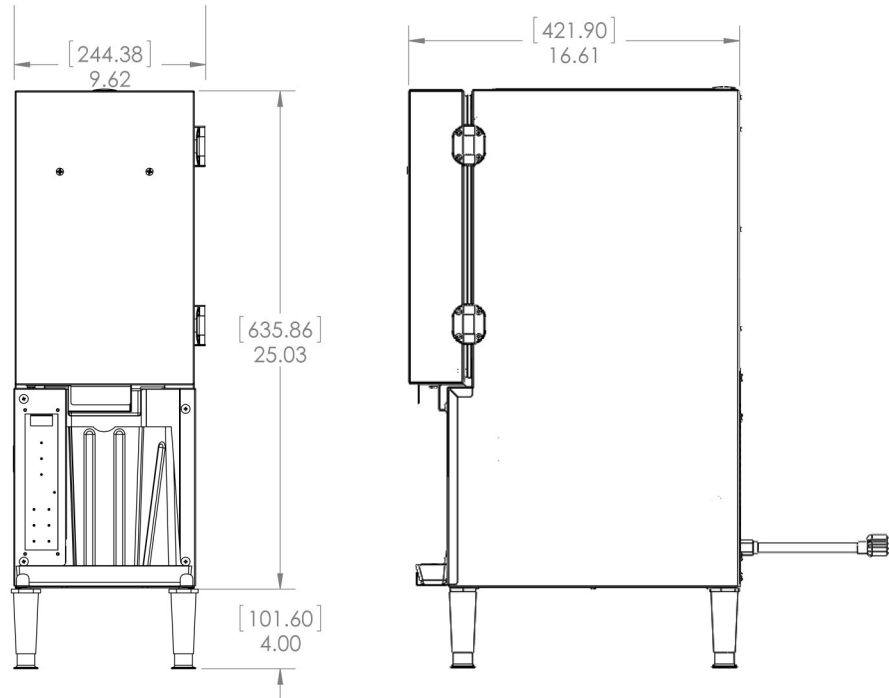

Dimensions

Model	Width in (cm)	Height in (cm)	Depth in (cm)	Gross Shipping Weight lb (kg)	Unit Net Weight lb (kg)	Shipping cu.ft. (cu.m.)
SK-1	9.62 (24.43)	29.03 (63.59)	16.61 (42.19)	70 (31.75)	65 (29.48)	4.98 (0.14)

Electrical

Model Number	Voltage	Amps	Nema Plug
SK-1	110-120 VAC	1.2	5-15 P

Certifications

